

ASIO Series

ASIO Series

Focal Length	7mm	13mm	25mm	50mm	100mm	50/250 DFOV
F#	2.3	2.3	2.3	2.3	2.3	2.3
Wavelength	3-5 μ	3-5 μ	3-5 μ	3-5 μ	3-5 μ	3-5 μ
Image Diagonal (mm)	21	21	21	21	21	21
Stop size (mm)	11	11	11	11	11	11
Stop position (mm)	25.4	25.4	25.4	25.4	25.4	25.4
BWD (mm)	33.1	33.1	33.1	33.1	33.1	33.1
Flange to F.P. (mm)	39.4	39.4	39.4	39.4	39.4	39.4
Mount Type	B	B	B	B	B	B
***Circular FOV	110°	75°	45°	23°	11°	23°/4.8°
Weight (g)	500	227	227	213	880	4083
**Min. Obj. Dist. (mm)	30	50	200	500	1750	n/a
Focus Type	M	M	M	M	M	MT
* Transmission (typical)	95%	92%	92%	92%	92%	81%

***Based on the listed Image Diagonal, FOV will vary depending on focal plane size.

**Closest an object can be focused in on.

*Over the primary waveband, 3 μ -5 μ .

B = Bayonet mount
M = Manual focus
MT = Motorized focus
DFOV = Dual Field of View

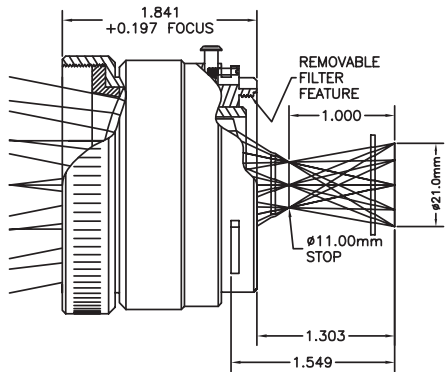

ASIO Series

Many years ago the infrared camera companies standardized the back working distance, stop location and F# for MWIR systems. The Asio line supports these imagers, and is designed to create an image size large enough to support the focal planes of the past and present. With the wide range of applications, this line has the largest selection available including single FOV, multi FOV and microscopes. It attaches to the camera with a bayonet mount, and there are a number of optional accessories available.



Microscopic Objectives

For close inspection of small components using infrared imagery, Janos has designed a line of microscope objectives for mid-wave thermal imagers. The line includes magnifications of 1x, 2.5x, and 4x. The front objective section is interchangeable with the same "eyepiece" that mounts to the camera. Every effort was made to maximize the distance from the lens to the object being inspected. These lenses interface with the bayonet mount.



Dual Field of View

Janos now offers a dual field of view (DFOV) lens that has motorized control for switching fields, and focus adjustment. You will be able to zoom in on, or out from, your object in under one second, and be able to program focus positions in each field. A special feature of this lens is the ability to focus in closely to objects in each field. The electronics are housed within the optical assembly, and a base plate accessory is available as a common mount between the lens and camera. This lens interfaces with the bayonet mount.



One Degree Field of View

For infrared imaging of objects at extreme distances, Janos offers the One Degree Field of View lens. This lens system was designed in a Catadioptric style to minimize size and weight, while maintaining optimal optical performance. This lens is focused manually, and interfaces with the bayonet mount. Please contact us for more information on this lens.

THE POWER OF FOCUS